

# Venous Collateral Circulation of the Extracranial Cerebrospinal Outflow Routes

Paolo Zamboni<sup>\*,1</sup>, Giuseppe Consorti<sup>2</sup>, Roberto Galeotti<sup>1</sup>, Sergio Giancesini<sup>1</sup>, Erica Menegatti<sup>1</sup>,  
Giovanna Tacconi<sup>1</sup> and Francesco Carinci<sup>2</sup>

<sup>1</sup>*Vascular Diseases Center, University of Ferrara, Ferrara, Italy*

<sup>2</sup>*Department of Maxillofacial Surgery, University of Ferrara, Ferrara, Italy*

**Abstract:** A new nosologic vascular pattern that is defined by chronic cerebrospinal venous insufficiency (CCSVI) has been strongly associated with multiple sclerosis. The picture is characterized by significant obstacles of the main extracranial cerebrospinal veins, the jugular and the azygous system, and by the opening of substitute circles. The significance of collateral circle is still neglected. To the contrary, substitute circles are alternative pathways or vicarious venous shunts, which permit the drainage and prevent intracranial hypertension. In accordance with the pattern of obstruction, even the intracranial and the intrarachidian veins can also become substitute circles, they permit redirection of the deviated flow, piping the blood towards available venous segments outside the central nervous system. We review the complex gross and radiological anatomy of collateral circulation found activated by the means of EchoColor-Doppler and selective venography in the event of CCSVI, focusing particularly on the suboccipital cavernous sinus (SCS), the condylar venous system, the pterygoid plexus, the thyroid veins, and the emiazygous-lumbar venous anastomosis with the left renal vein.

**Keywords:** Cerebrospinal venous insufficiency (CCSVI), multiple sclerosis (MS), cerebral venous system, collateral circulation.

## INTRODUCTION

A new nosologic vascular pattern recently identified, defined as chronic cerebrospinal venous insufficiency (CCSVI) is strongly associated with multiple sclerosis (MS) (Zamboni *et al.*, 2009a).

CCSVI is characterized by multiple stenoses/obstruction affecting the principal extracranial outflow pathways of the cerebrospinal venous system, the internal jugular veins (IJVs) and azygous vein (AZY), distributed in four main patterns. CCSVI determines significant changes in cerebral venous hemodynamics, with a very high incidence of reflux in both intracranial and extracranial venous segments, and loss of the postural regulation of cerebral venous outflow (Zamboni *et al.*, 2007, Zamboni *et al.*, 2009a and 2009b; Franceschi, 2009).

Venous obstructions are compensated by substitute circles. Substitute circles are alternative pathways or vicarious venous shunts that allow for the piping of blood towards available venous segments outside the central nervous system (CNS).

In accordance with the pattern of obstruction, both the intracranial and the intrarachidian veins can also become substitute circles, they permit redirection of the deviated flow, preventing intracranial hypertension. However, over time, they become overloaded because they carry two

different flows, their own draining flow and the shunted flow (Zamboni *et al.*, 2009a; Franceschi, 2009; Zamboni *et al.*, 2007).

There are no current reviews clearly indicating the collateral circles activated in case of stenosis of the main extracranial cerebral venous paths.

## SCHEMATIC ANATOMIC ORGANIZATION OF THE VENOUS SYSTEM OF THE BRAIN

Cerebrovenous system (CVS) is a three-dimensional structure that is often asymmetric and considerably represents more variable pattern than the arterial anatomy (Schaller, 2004).

The CVS is mainly composed of dural sinuses and cerebral veins (Hassler, 1966; Meder *et al.*, 1994; Muizelaar, 1989).

The venous outflow from cerebral hemispheres consists mainly of two different vascular systems (Andeweg, 1989):

- *the superficial (cortical) system* reaches dural sinuses by cortical veins and drains blood mainly from cortex and subcortical white matter (Meder *et al.*, 1994; Aydin *et al.*, 1997);
- *the deep cerebral venous system (medullary or subependymal)* (DCVs) is composed by subependymal veins, internal cerebral veins, basal vein and great cerebral vein of Galen and their tributaries, and drains the deep white and gray matter surrounding the lateral and third ventricles or blood from cortical regions (Meder *et al.*, 1994; Ono *et al.*, 1997).

\*Address correspondence to this author at the University of Ferrara, C.so Giovecca203, 44100 Ferrara, Italy; Tel: +390532236524; Fax: +390532237443; E-mail: zmp@unife.it

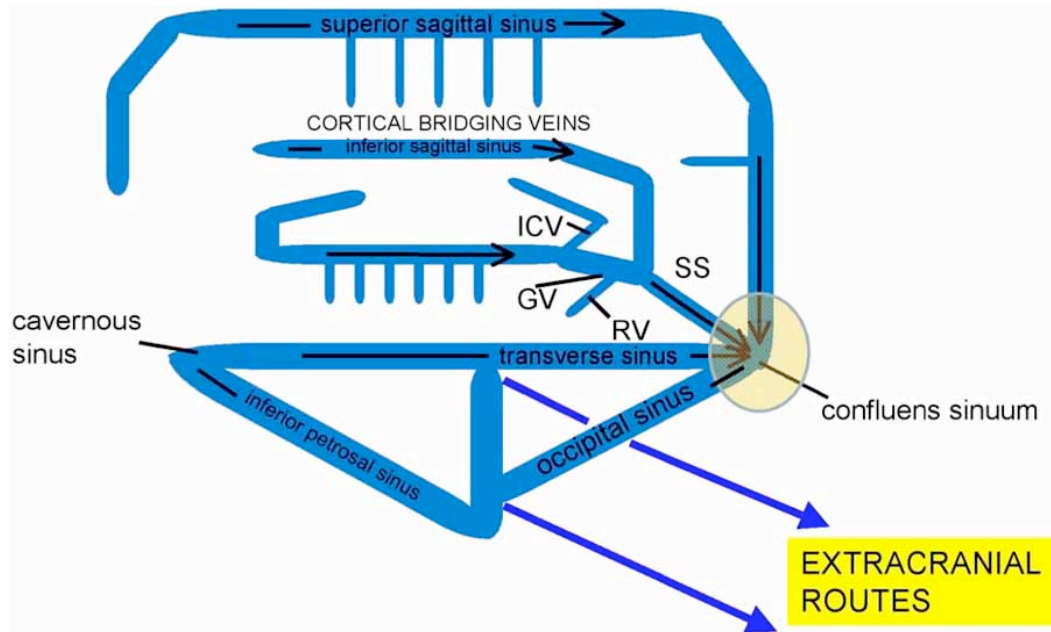

**Fig. (1). Schematic organization of the cerebral venous system.** Flow is monodirectional according to the hierarchical order of emptying showed in the figure. The deep cerebral veins are respectively depicted: ICV refers to internal cerebral vein, GV to Galen vein, RV to Rosenthal vein. They finally drain into the straight sinus (SS).

### Cortical System Draining Routes

The superficial middle cerebral vein runs along the Sylvian cistern and drains the anterior temporal lobe, parasylvian cortex and anterior– inferior frontal lobes (Reisch *et al.*, 2002). It subsequently empties into cavernous sinus, sphenoparietal sinus or pterygoid plexus (Schaller, 2004; Reisch *et al.*, 2002).

It is formed by anastomosis of temporo-sylvian veins. These veins are connected with midline bridging veins on one side and juxta-basal temporal veins on the other, and enter predominantly the cavernous sinus, either directly or through the sphenoparietal sinus (Reisch *et al.*, 2002). Many anatomical variations are possible: (1) in size: when very thin or even absent, neighboring veins become of greatest importance, (2) in termination: draining towards the pterygoid plexus or the superior petrosal sinus (Schaller, 2004; Huther *et al.*, 1998; Reisch *et al.*, 2002).

The superior sagittal sinus (SSS) starts at the foramen cecum, just anterior to the crista galli (Mehta *et al.*, 2000). It courses along the gentle curvature of the inner table of the skull, within the leaves of the dura mater, to reach the confluence of sinuses: the torcular Herophili (Ayanzu *et al.*, 2000). Along the way, the sinus receives the cortical bridging veins. After the subarachnoid course, they penetrated the SSS at different points in the dura mater depending on their rostrocaudal position (Fig. 1). Histologically the organization of the smooth muscle cells at the end of each cortical vein quite resembles a myoendothelial “sphincter”. Some authors hypothesize that such myoendothelial junction acts as smooth sphincter and that it plays a role in cerebral venous hemodynamics regulation (Vignes *et al.* 2007).

The SSS vascular caliber increases from anterior to posterior, because of the penetration of arachnoid villi inside

its lumen (Ayanzu *et al.*, 2000). The SSS is circulating in a more or less laminal way, accentuated by the existence of longitudinal septa, especially in midthird portion. Lateral sinuses drain the SSS, equally on both sides in only 20% of cases and asymmetrically in more than 50%, depending upon configuration of torcular Herophili (Schaller, 2004; Suzuki *et al.*, 2001). In extreme, one lateral sinus may drain SSS in totality (most often on right side) and the other one the straight sinus; this accounts for 20% of the cases (Schaller, 2004; Suzuki *et al.*, 2001). Atresia of the transverse sinus or even the agenesis on one side was observed in 17% of cases (Suzuki *et al.*, 2001). So that the remaining sigmoid sinus drains the inferior cerebral veins (*i.e.* the Labbe’ system). The sigmoid sinus drains the posterior fossa (Reisch *et al.*, 2002) receiving the superior and inferior petrosal sinuses (IPS) and sometimes veins coming from the lateral aspect of brainstem and medulla (Suzuki *et al.*, 2001). Sigmoid sinus has frequent anastomosis with cutaneous venous network through mastoid emissary vein (Schaller, 2004; Suzuki *et al.*, 2001). When the sigmoid segment of the lateral sinus is atretic, the transverse sinus with its affluent drains toward the opposite side (Schaller, 2004; Suzuki *et al.*, 2001). The inferior sagittal sinus (ISS) follows a similar curve within the free margin of the falx cerebri (Wetzel *et al.*, 1999). Often, its anterior portion is deficient and the sinus appears more linear than curvilinear. In contrast to its superior counterpart, the ISS empties into straight sinus, at or near its communicating vein with the vein of Galen (Schaller, 2004; Wetzel *et al.*, 1999). The straight sinus, therefore, drains the deep venous system through the vein of Galen, as well as much of superficial venous system indirectly through the ISS and basal vein (Schaller, 2004; Suzuki *et al.*, 2001). As all other sinuses, the straight sinus is situated within dural leaves, in this case, of tentorium cerebelli and falx cerebri (Schaller, 2004; Wetzel *et al.*, 1999). Posteriorly, straight

sinus empties into torcular (Schaller, 2004; Wetzel *et al.*, 1999). Another complex network of dural sinuses collects blood along the brain's ventral surface (Ayanzu *et al.*, 2000) including the cavernous, superior and inferior petrosal, and sphenoparietal sinuses. Cavernous sinus is a trabeculated dural venous packet along parasellar sphenoid bone (sphenoid sinus) (Schaller, 2004; Chanda, 2002). The sinus extends from superior orbital fissure to petrous apex. Its venous inflow includes orbital venous drainage (superior and middle ophthalmid veins), anterior middle cranial fossa drainage (superior and inferior middle cerebral veins) and sphenoorbital sinus. From cavernous sinus, blood drains posterolaterally along superior petrosal sinus to transverse sinus and inferior-laterally along IPS into jugular (Schaller, 2004; Suzuki *et al.*, 2001). Deep sinuses also interconnect by way of the basilar venous plexus along the dorsal clivus and the intercavernous sinus among the pituitary infundibulum. Occasionally, a prominent venous plexus connects the cavernous sinuses along the floor of the sella turcica.

### Deep System Draining Routes

The subcortical and deep white matter are drained by DCVs (Schaller, 2004; Andeweg, 1989) that originate 10–20 mm below the cortex and course centrally to the subependymal veins that surround the ventricles (Friedman, 1997; Hooshmand *et al.*, 1974). The subependymal veins drain from the deeper subcortical structures, such as internal and external capsule, the basal ganglia, and the dorsal part of the diencephalon, to the vein of Galen, which curves around the posterior surface of the splenium of the corpus callosum before terminating at the confluence of sinuses (Fig. 1) (Hooshmand *et al.*, 1974). Except from the anatomical variations of the basal veins, the system of the DCVs remains relatively constant compared to the superficial cortical venous system (Schaller, 2004; Huther, *et al.*, 1998; Reisch *et al.*, 2002).

The DCVs can be subdivided into two different subgroups: i) the superficial branches drain 1–2 cm of white matter and course through the gray matter (Schaller, 2004; Okudera *et al.*, 1988). They are connected to the cortical veins, ii) the deep branches begin within the white matter deeper than superficial medullar veins and course toward lateral ventricles, emptying into the subependymal veins of the walls of the lateral ventricle (Schaller, 2004; Friedman, 1997). A third group of DCVs defined as “transcerebral veins” completely transverse the hemisphere to reach subependymal veins (Schaller, 2004; Hassler, 1966; Huang *et al.*, 1964). All these white matter veins run perpendicular to the long axis of the lateral ventricle, creating a fem-shaped appearance (Lee *et al.*, 1996).

Three DCVs are commonly seen on the venous phase of a cerebral arteriogram (Capra, 1984; Mattle *et al.*, 1991): (1) thalamostriate vein, (2) septal vein, and (3) internal cerebral vein. The thalamostriate veins join the septal veins from the internal cerebral veins (Schaller, 2004; Scott *et al.*, 2003; Teksum *et al.*, 2003). The point at which the anterior vein of the septum pellucidum joins the superior thalamostriate vein is called the venous angle and is usually located at the interventricular foramen (Scott *et al.*, 2003). The internal cerebral veins are paired and run above the roof of the third ventricle (Schaller, 2004; Scott *et al.*, 2003). These veins are

joined by basal veins of Rosenthal forming the vein of Galen (Schaller, 2004; Scott *et al.*, 2003) (Fig. 1). The basal vein of Rosenthal represents the confluence of veins draining basal and medial parts of frontal lobe, temporal lobe, basal ganglia, and insula (Schaller, 2004; Scott *et al.*, 2003). Occasionally, basal vein of Rosenthal can drain aberrantly into a tentorial sinus or superior petrosal sinus (Schaller, 2004; Scott *et al.*, 2003).

### Extracranial Venous Drainage

The cerebral blood is finally collected into the dural sinuses and in turn redirected towards the main extracranial venous outflow routes: the IJVs and the vertebral venous system (Fig. 1). The anatomical pathways of jugular drainage are well established. The main jugular blood drainage pathway leads from the SSS and the transverse sinuses *via* the sigmoid sinuses into the IJVs, which meet the superior cava vein *via* the brachiocephalic vein.

Several ultrasound study of healthy volunteers demonstrated that the pattern of cerebral venous drainage changes, even under physiological conditions, depending on the body position (Valdúeza *et al.*, 2000; Doepp *et al.*, 2004; Schreiber, *et al.* 2003; Menegatti and Zamboni, 2008).

In the prone position, the outflow through the IJVs is favored, this assumption was based on angiographic studies and cerebral blood flow analyses with nitrous oxide, labeled erythrocytes, and thermodilution techniques (Schreiber *et al.*, 2003; Nylin *et al.*, 1961; Huber, 1982; Shenkin *et al.*, 1948; Wilson *et al.*, 1972), which were all performed in a supine body position. Whereas passing to the upright position transfers most of the encephalic drainage to the VVs (Valdúeza *et al.*, 2000; Doepp *et al.*, 2004; Menegatti and Zamboni, 2008).

### Extracranial Draining Pathways of the Vertebral System

Vertebral venous system is a freely communicating, valveless system present throughout the entire spinal column and may be divided into an internal intraspinal part, the epidural veins, and an extraspinal paravertebral part.

- 1) At the craniocervical level, anterior sources of intraspinal system arise from basal plexus and IPS (Schaller, 2004; Chaynes, 2003). A posterior communicating venous drainage exists with occipital sinus, which may be relevant in cases of lateral sinus hypoplasia (Schaller 2004). The system communicates with deep thoracic and lumbar veins, intercostal veins, AZY, and hemiazygous veins, as well as with the inferior vena cava. Particularly, the collateral circle between the AZY and the inferior vena cava, *via* the left renal vein is particularly relevant in course of CCSVI. The AZY in the MS group was obstructed in 86% of cases. Most cases involved membranous obstruction of the junction with the superior vena cava, twisting, or, less frequently, septum and atresia (Zamboni *et al.*, 2009a). In such cases, descending venography documented a reflux flow along the AZY system, which re-enters into the caval system through the hemiazygous-lumbar anastomosis with the left renal vein (Fig. 2). In type B pattern of CCSVI, characterized by significant stenoses of both IJVs

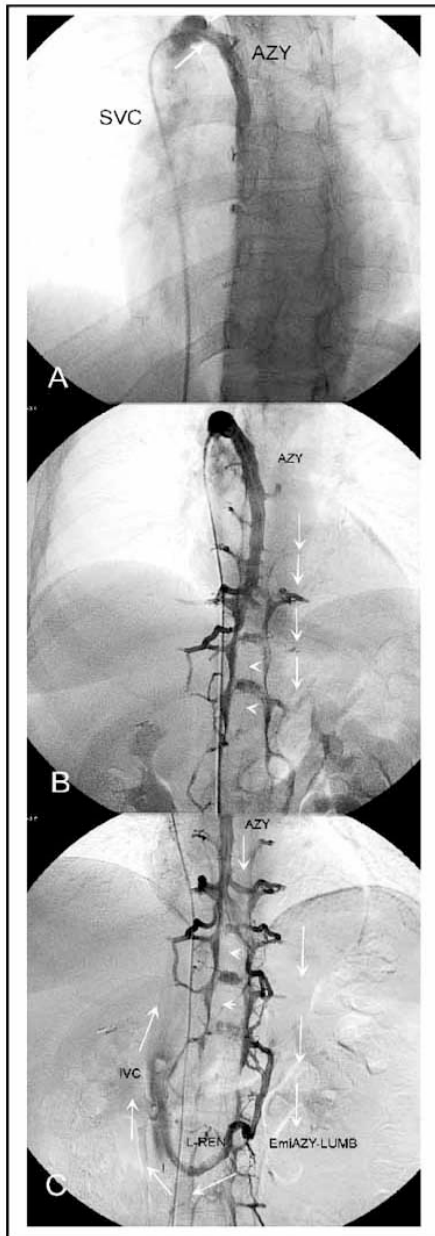

**Fig. (2).** Selective venography of the azygous system. **A)** Descending venography of the AZY with proximal stenosis indicated by arrows. **B)** Low dose injection (3 ml/sec) below the stricture documents a reflux downward the AZY (arrows) due to the impossibility to empty into the superior vena cava (SVC). **C)** The blood can be drained only through the intra-extra spinal veins (horizontal arrows); or, alternatively, *via* the emiazygous and lumbar veins (emiazy, LUMB). The latter pathway allows to re-entry, *via* the left renal vein (L REN), into the inferior caval system (IVC).

combined with proximal strictures of the proximal AZY, such a collateral circle becomes the main extracranial pathways for draining the CNS (Zamboni *et al.*, 2009a). Obstruction of the superior vena cava

cranially from the AZY vein is tolerated well, but obstruction involving connection of termination of AZY vein to heart leaves collateral flow only towards inferior vena cava, which results in insufficient cranial venous outflow (Hoffmann *et al.*, 2002).

- 2) The extraspinal system receives blood anteriorly from cavernous sinus *via* pterygoid plexus (Schaller, 2004). A dorsal part is connected to suboccipital venous plexus, which receives blood through mastoid and condylar emissaries (Schaller, 2004; Brew, 2004). Although the jugular veins were previously thought to be the predominant draining pathway (Cowan *et al.*, 1983), anatomical recent study-findings have demonstrated that this role is confined to the supine position; redirection of venous flow to the vertebral veins occurs in upright-position (Schaller *et al.*, 2004; Schreiber *et al.* 2003; Hoffmann *et al.*, 2002). The vertebral veins (VVs) are Part of the vertebral system, which have been shown to serve as venous collaterals in cases of jugular flow obstruction (Schreiber *et al.*, 2003). The VVs represent the main longitudinal part of the external vertebral venous system. VVs and the deep cervical veins, which are located within the muscle layers of the nape, receive inflow from the marginal and sigmoid sinuses *via* condylar veins and emissaries and from the venous plexus surrounding the foramen magnum (Schreiber *et al.*, 2003). In addition, there are several frequently segmental connections between the internal and external parts of the vertebral venous system. VVs, deep cervical veins, and the external jugular vein finally join the brachiocephalic vein.

#### Anastomoses of Intra- and Extracranial Veins

Batson (Schaller *et al.*, 2004; Batson, 1967) described vessel-connections between intra and extracranial veins at cranial base as a single large venous plexus, and this appears to be the most practical view: (1) The suboccipital venous plexus represents the cranial beginning of the posterior external vertebral plexus between the dorsal muscles, it is connected to the sigmoid sinuses *via* mastoid and condylar emissaries (Fig. 3) (Pedley *et al.*, 1998). (2) The posterior internal vertebral plexus receives blood from occipital sinus and, thus, from confluens sinus (Pedley *et al.*, 1998). The latter is often plexiform and asymmetrical, and when one lateral sinus is narrow or absent, occipital sinus is larger than usual, and in neonates the occipital sinus is very large (Batson, 1967; Pedley *et al.*, 1998). (3) The anterior internal vertebral plexus is a continuation of basal plexus, which lies on clivus and connects IPS and both cavernous sinuses (Pedley *et al.*, 1998). (4) The anterior external vertebral plexus is a continuation of large pterygoid plexus, which receives blood from cavernous sinuses (Fig. 4) (Batson, 1967; Pedley *et al.*, 1998).

The pharyngeal venous plexuses may play a role in the anterior region that should not be ignored. The plexus communicates with the intracranial venous sinus through the pterygoid venous plexus, and draining into the internal jugular vein, and/or into the laryngeal and tracheal venous plexus (Fig. 4).

Besides these affluent pathways, the outflow channels of vertebral plexuses can also be summarized (Schaller, 2004; Batson, 1967): (1) in the thoracolumbar area, outflow from vertebral plexuses takes place *via* the lumbo-hemiazygous system, which also forms a collateral channel between inferior and superior vena cava. Valves in the AZY system are superior rudimentary and nonfunctioning. (2) In vertebral plexuses of cervical area, longitudinal collecting channels besides internal jugular vein on either side are deep cervical vein posteriorly between muscles, vertebral vein (through the transverse process of the cervical vertebrae) and, subcutaneously, external jugular vein (Batson, 1967). These veins join subclavian and internal jugular veins in forming brachiocephalic vein (Batson, 1967).

**THE CONCEPT OF VICARIOUS VENOUS SHUNT IN COURSE OF CCSVI**

Venous function is a central mechanism of regulation of cell and tissue biology, although there is a lack of study on its influence in the central nervous system (CNS). It has been recently illustrated a vascular picture that has not previously been described, correctly defined as chronic cerebrospinal venous insufficiency (CCSVI), strongly associated with MS (Zamboni *et al.*, 2009a,b; Zamboni *et al.*, 2007; Franceschi, 2009). The picture is characterized by significant obstacles of the main extracranial cerebrospinal veins, the jugular and AZY system, and by the opening of substitute circles. When the venous flow is deviated into collaterals to bypass an obstacle, there exists what is called a vicarious shunt (Franceschi, 1996). This type of shunt is desirable because it bypasses blocked veins and, thereby, reduces resistance to

drainage. It flows permanently under the effects of distal cardiac residual pressure and proximal thoracoabdominal aspiration. However, the expected time of venous outflow is longer, as confirmed by the mean transit time measured in MS patients by the means of MR perfusional study, even in normal-appearing white matter (Law *et al.*, 2004).

The significance of the shunt depends on the overload of the volume of blood that is deviated, the starting-point and end-point of the deviation (Franceschi, 1996). Shunts may be directed outward, but in the case of CCSVI, a retrograde flow has been demonstrated in the majority of cases, meaning reflux in the CNS.

The main deep cerebral veins, the transversal sinus, the IJVs and the VVs and the AZY were deeply investigated with Eco Color-Doppler and selective venography in the event of CCSVI (Zamboni *et al.*, 2007; Zamboni *et al.*, 2009a,b). These investigations showed the activation of collateral pathways described in this review, underlying the importance of such venous vicarious pathways when the principal extracranial outflow routes are obstructed. We extensively review in the further paragraph the main vicarious shunt activated in course of CCSVI, because such pathways permit to avoid intracranial hypertension in such cases.

**Suboccipital Cavernous Sinus (SCS) and Condylar Vein**

The SCS is a structure surrounding the internal carotid artery, it anatomically resembled the vertebral venous plexus surrounding the horizontal portion of the vertebral artery at the skull base.

base.

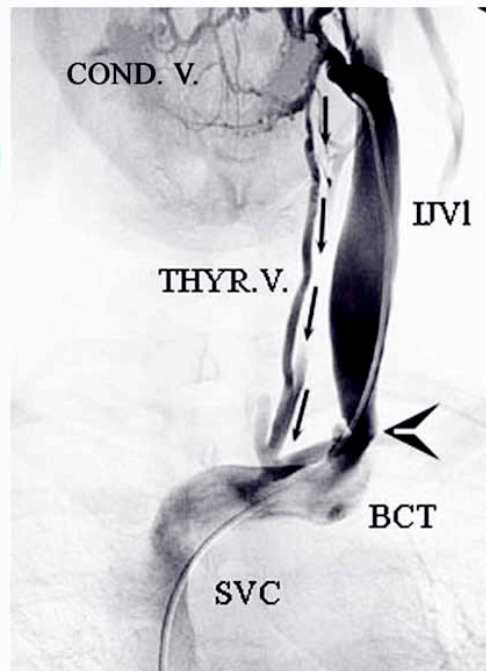
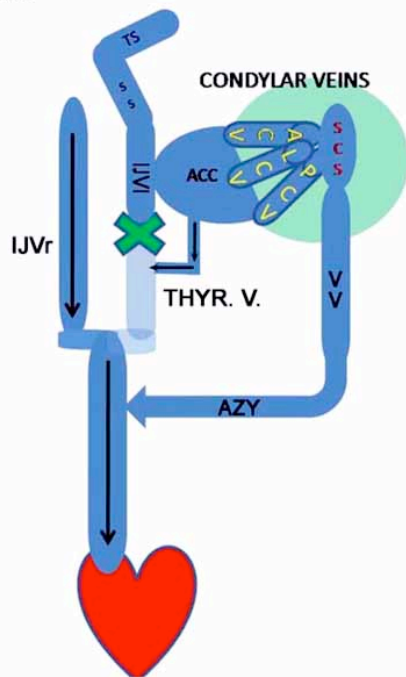

**Fig. (3).** The condylar venous system vicarious shunt. Left: Schematic exemplificative obstruction of the IJVI in course of CCSVI associated to MS. The 3 condylar veins, connected respectively with the thyroid veins and with the VVs, become a preferential substitute circle. Right: RX selective venography of a severe stenosis of the IJVI (arrow). The condylar veins (COND.V.) pipe blood toward the thyroid veins (THYR.V.), and the brachiocephalic trunk (BCT) and the superior vena cava (SVC).

Arnautovic *et al.* (Arnautovic *et al.*, 1997; Takahashi *et al.*, 2005) revealed the SCS to be connected with the following venous structures: anterior condylar vein (ACV), posterior condylar vein (PCV), lateral condylar vein (LCV), anterior internal vertebral venous plexus (AVVP), and vertebral artery venous plexus (VAVP) surrounding the vertical portion of the vertebral artery, and internal vertebral venous plexus. The SCS is an important outflow tract of the vertebral venous system that would play an important role in venous obstructive disease. The SCS sinus connects indirectly the internal vertebral venous plexus to the dural venous sinuses of the skull base (Fig. 3).

The ACV and PCV were defined as follows according to international anatomic nomenclature: ACV, venous plexus of the hypoglossal canal that drains through the hypoglossal canal (anterior condylar canal); PCV, condylar emissary vein that drains through the posterior condylar canal as described by San Millan Ruiz *et al.* (San Millan Ruiz *et al.*, 2002; Takahashi *et al.*, 2005). The ACV, PCV, and LCV are connected with both the jugular bulb and SCS. In an MR imaging study, Caruso *et al.* (Caruso *et al.*, 1998; Takahashi *et al.*, 2005) reported that the ACV connected with the SCS through the marginal sinus. Moreover, San Millan Ruiz *et al.* (San Millan Ruiz *et al.*, 2002; Takahashi *et al.*, 2005) described the marginal sinus as connecting anteriorly with the ACV, sometimes forming a bridge between the ACV and suboccipital vein. Although the portion of the ACV described herein may represent part of the marginal sinus, the presence of the marginal sinus could not be confirmed, as no circular filling occurred around the foramen magnum on bilateral anterior condylar venography.

The ACV and LCV communicate with each other at the external orifice of the hypoglossal duct. This meeting point was termed the “anterior condylar confluent” (Fig. 3) (San Millan Ruiz *et al.*, 2002; Takahashi *et al.*, 2005).

In a study of microsurgical anatomy, Katsuta *et al.* (Katsuta *et al.*, 1997; Takahashi *et al.*, 2005) described a venous confluence at the lower end of the IPS that drained into the medial aspect of the jugular bulb, naming this the “petrosal confluence”. They found the IPS connected with the anteromedial portion of the jugular bulb, while the ACV communicated with the posteromedial portion of the jugular bulb. The “petrosal confluence” and “anterior condylar confluent” may, thus, represent the same structure, or be located in the very near vicinity.

The PCV was defined to international anatomic nomenclature condylar emissary vein that drains through the posterior condylar canal. The PCV connected with the posteromedial aspect of the jugular bulb and supero-posterior aspect of the SCS.

The cranial connections of the anterior internal vertebral venous plexus with the anterior condylar vein could offer a cranial escape route for thoracic and abdominal venous return when thoracic pressure and abdominal pressure are increased concomitantly. One could even consider venous blood from the anterior internal vertebral venous plexus draining into the superior ophthalmic vein and cavernous sinus through the basilar plexus and IPS and, thus, terminally into the pterygoid plexus and facial veins (Fig. 4). Parkinson recently described the extradural neural axis compartment

(Parkinson, 2000; San Millan Ruiz *et al.*, 2002). The extradural neural axis compartment contains a continuum of veins that extends from the ophthalmic to the coccygeal veins and offers numerous longitudinal and transverse venous anastomoses. In the craniocervical region, the basilar plexus, inferior petrosal sinuses, and anterior condylar veins represent the venous elements of this extradural neural axis compartment.

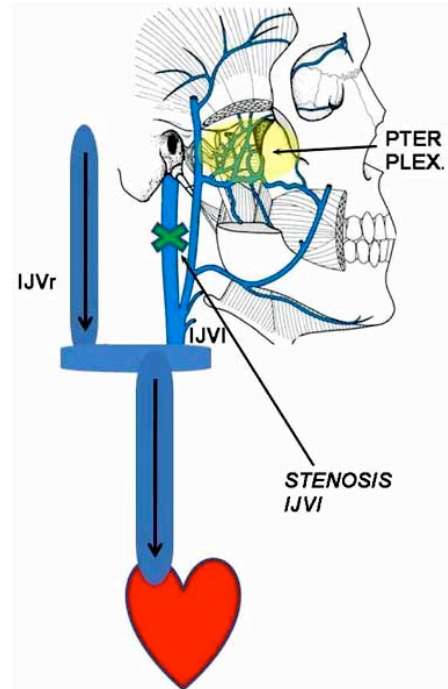

**Fig. (4).** The pterygoid plexus vicarious shunt. Left: The pterygoid plexus (PTER. PLEX.) is one of the preferential intra extra cranial venous anastomoses found activated in course of CCSVI (in the figure example closed obstruction of the IJVI).

#### Anterior Condylar Confluent (ACC)

This venous confluent is located extracranially in front of the aperture of the hypoglossal canal and was described by Trolard as far back as 1868 (Trolard, 1868; San Millan Ruiz *et al.*, 2002).

The size of the ACC varies from 3 to 5 mm in an anterior view and approximately 2mm in its ventrodorsal extension in the MR venography images (San Millan Ruiz *et al.*, 2002).

The following veins regularly contributed in forming the ACC (San Millan Ruiz *et al.*, 2002): 1) the anterior condylar vein, 2) one or several branches from the internal jugular vein or its bulb, 3) the lateral condylar vein, sometimes arising from one or several branches from the internal jugular vein or its bulb, 4) anastomoses with the IPS at a variable distance from its termination into the internal jugular vein, 5) branches from the internal carotid artery venous plexus of Rektorzik, corresponding to Trolard's inferior petrooccipital vein (Trolard, 1868; San Millan Ruiz *et al.*, 2002) found coursing extracranially along the petro-occipital suture, and 6) branches from the prevertebral venous plexus found on the anterior atlanto-occipital membrane.

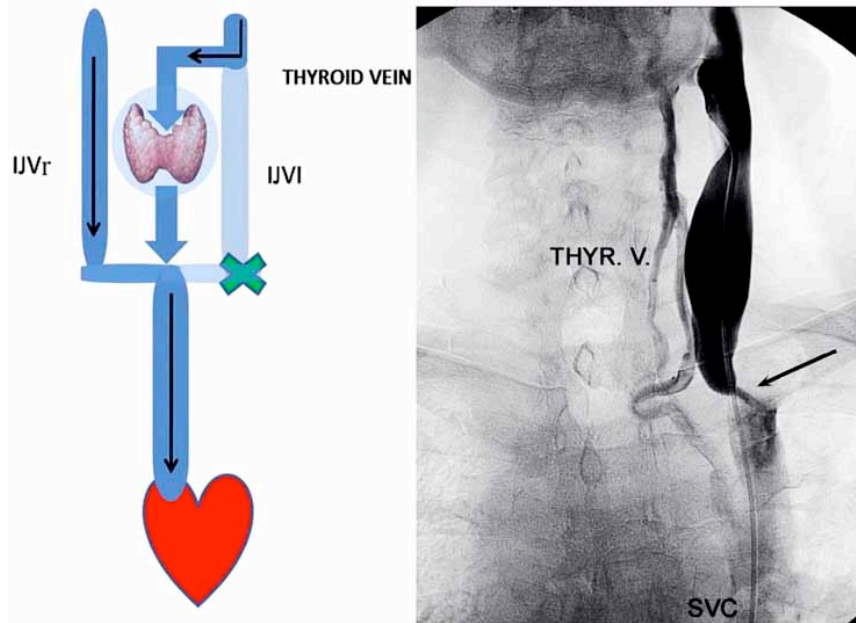

**Fig. (5). The thyroideal veins vicarius shunt.** Left: Exemplificative obstruction of the IJVI bypassed by the thyroid veins. Right: RX selective venography showing a 95% stenosis of the IJVI in corse of CCSVI associated to MS, with corresponding vicarious shunt of the thyroid veins (THYR.V.) toward the superior vena cava (SVC).

The numerous anastomoses of the ACC make it a crossroad between the cavernous sinus, dural venous sinuses of the posterior fossa, and posterior cervical outflow tracks.

All the major tributaries of the ACC and outflow pathways of the cerebral venous system were shown on the phlebographic images.

### Pterygoid Plexus

This venous plexus lies around and partly within the lateral pterygoid muscle. Its tributaries correspond to the branches of three parts of the maxillary artery although the area drained is somewhat smaller than that supplied by artery. Blood from the periphery of the latter area drains *via* other routes, such as the facial veins. The pterygoid plexus also communicates with the facial vein through the deep facial vein, with the cavernous sinus by means of one or more emissary veins passing through the foramen ovale (or the emissary sphenoidal foramen if present) and with the inferior ophthalmic vein through the inferior orbital fissure. It drains through the short but wide maxillary vein, which runs between the neck of the mandible and the sphenomandibular ligament to unit with the superficial temporal vein and form the retromandibular vein. The plexus may be difficult to find in the cadaver where it is empty of blood but in the living subject it is frequently a prominent structure.

### Cervical Anastomosis: The Thyroid Veins

The superior, middle, and inferior thyroid veins all drain their respective lobes. The superior and middle thyroid veins drain into the IJVs, whereas the inferior thyroid vein drains into the brachiocephalic trunk. Such a collateral circle has been seen constantly activated when chronic obstruction of the IJVs occurred (Zamboni *et al.*, 2009a). It permits to

bypass stenoses of the distal IJVs segment collecting the blood towards the brachiocephalic trunk (Fig. 5).

### CONCLUSIONS AND REMARKS

The blood leaves the brain though a very complex anatomical apparatus, with really high variability. The present review provides a simplified description of the functional organization of the extra and intracranial main pathways, as well as of the main extra-intracranial and/or extracranial collateral circulation. The knowledge of the main collateral pathways is really relevant in a number of clinical situations, including also the recent description of CCSVI associated to MS. In the latter, substitute circle permits to drain blood sufficiently to avoid intracranial hypertension.

### ACKNOWLEDGEMENT

We wish to thanks for the support Hilarescere Foundation, Bologna, Italy.

### ABBREVIATIONS

ACC	=	Anterior condylar confluent
ACV	=	Condylar vein
AVVP	=	Anterior internal vertebral venous plexus
AZY	=	Azygous vein
CCSVI	=	Chronic cerebrospinal venous insufficiency
CNS	=	Central nervous system
CVS	=	Cerebrovenous system
IJVs	=	Internal jugular veins

IPS	=	Inferior petrosal sinuses
ISS	=	Inferior sagittal sinus
LCV	=	Lateral condylar vein
MS	=	Multiple sclerosis
PCV	=	Posterior condylar vein
SCS	=	Suboccipital cavernous sinus
SCS	=	Suboccipital cavernous sinus
SSS	=	Superior sagittal sinus
VAVP	=	Vertebral artery venous plexus
VVs	=	Vertebral veins

## REFERENCES

- Andeweg, J. (1989) Intracranial venous pressure, hydrocephalus and effects of cerebrospinal fluid shunts. *Child's Nerv Syst* 5: 318-323.
- Andeweg, J. (1996) The anatomy of collateral venous flow from the brain and its value in aetiological interpretation of intracranial pathology. *Neuroradiology* 38: 621-628.
- Arnautovic, KI, Al-Mefty, O, Pait, TG, Krisht, AF, Husain, MM. (1997) The suboccipital cavernous sinus. *J Neurosurg* 86: 252-262.
- Ayanzen, RH, Bird, CR, Keller, PJ, McCully, FJ, Theobald MR, Heiserman, JE. (2000) Cerebral MR Venography: Normal Anatomy and Potential Diagnostic Pitfalls. *Am J Neuroradiol* 21: 74-78.
- Aydin, IH, Tuzun, Y, Takci E, Kadioğlu, HH, Kayaoğlu, CR, Barlas, E. (1997) The anatomical variations of sylvian veins and cisterns. *Minim Invasive Neurosurg* 40: 68-73.
- Batson, OV (1967) The vertebral system of veins as a means for cancer dissemination. *Prog Clin Cancer* 3: 1-18.
- Brew, S. (2004) Normal galenic drainage of the deep cerebral venous system. *Child's Nerv Syst* 20: 98-99.
- Capra, NF, Anderson, KV. (1984) Anatomy of the cerebral venous system. *The Cerebral Venous System and its Disorders*. In: Kapp, JP, Schmidek, HH, Ed. Philadelphia: Grune and Stratton, pp. 1-36.
- Caruso, RD, Smith, MV, Chang, JK, Wasenko JJ, Rosenbaum, AE. (1998) Giant cervical epidural veins after craniectomy for head trauma. *Am J Neuroradiol* 19: 903-906.
- Chanda, A, Nanda, A. (2002) Anatomical study of the orbitozygomatic transsellar-transcavernous-transclinoidal approach to the basilar artery bifurcation. *J Neurosurg* 97: 151-160.
- Chaynes, P. (2003) Microsurgical anatomy of the great cerebral vein of Galen and its tributaries. *J Neurosurg* 99: 1028-1038.
- Cowan, F, Thorensen, M. (1983) Ultrasound study of the cranial venous system in the human new-born infant and the adult. *Acta Physiol Scand* 117: 131-137.
- Doepf, F, Schreiber, SJ, Von Münster T, Rademacher, J, Klingebiel, R, Valdueza, JM. (2004) How does the blood leave the brain? A systematic ultrasound analysis of cerebral venous drainage patterns. *Neuroradiology* 46: 565-570.
- Franceschi, C. (1996) Physiopathologie hémodynamique de l'insuffisance veineuse des membres inférieurs. In *Chirurgie des veines des membres inférieurs*, Kieffer, E, Bahnini, A, Ed. Paris: Editions AERCV, pp. 19-53.
- Franceschi, C. (2009) The unsolved puzzle of multiple sclerosis and venous function. *J Neurol Neurosurg Psychiatry* 80: 358.
- Friedman, DP. (1997) Abnormalities of the deep medullary white matter veins: MR imaging findings. *Am J Roentgenol* 168: 1103-1108.
- Haroun, A. (2005) Utility of contrast-enhanced 3D turbo-flash MR angiography in evaluating the intracranial venous system. *Neuroradiology* 47: 322-327.
- Hassler, O. (1966) Deep cerebral venous system in man: a microangiographic study on its areas of drainage and its anastomoses with superficial cerebral veins. *Neurology* 16: 505-511.
- Hoffmann, O, Klingebiel, R, Braun, JS, Katchanov, J, Valdueza, JM. (2002) Diagnostic pitfall: Atypical cerebral venous drainage via the vertebral venous system. *Am J Neuroradiol* 23: 408-411.
- Hooshmand, I, Rosenbaum, AE, Stein, RL. (1974) Radiographic anatomy of normal cerebral deep medullary veins. Critical for distinguishing them from their abnormal counterparts. *Neuroradiology* 7: 75-84.
- Huang, YP, Wolf, B. (1964) Veins of the white matter of the cerebral hemispheres (the medullary veins). *Am J Roentgenol* 92: 739-755.
- Huber, P. (1982) *Cerebral Angiography* 2<sup>nd</sup> ed. Stuttgart, Germany: Thieme Verlag.
- Huthner, G, Dorth, J, Van der Loos, H, Jeanmonod, D. (1998) Microanatomic and vascular aspects of the temporomesial region. *Neurosurgery* 43: 1118-1136.
- Jeevan, DS, Anslow, P, Jayamohan, J. (2008) Abnormal venous drainage in syndromic craniosynostosis and the role of CT venography. *Childs Nerv Syst* 24: 1413-1420.
- Katsuta, T, Rhoton, AL Jr, Matsushima, T. (1997) The jugular foramen: microsurgical anatomy and operative approaches. *Neurosurgery* 41: 149-202.
- Law, M, Saindane, AM, Ge, Y, Babb, JS, Johnson, G, Mannon, LJ, Herbert, J, Grossman, RI. (2004) Microvascular abnormality in relapsing-remitting multiple sclerosis: perfusion MR imaging findings in normal-appearing white matter. *Radiology* 231: 645-652.
- Lee, C, Pennington, MA, Kenney, CM. (1996) MR evaluation of developmental venous anomalies: medullary venous anatomy of venous angiomas. *Am J Neuroradiol* 17: 61-70.
- Mattle, HP, Wentz, KU, Edelman, RR, Wallner, B, Finn, JP, Barnes, P, Atkinson, DJ, Kleefeld, J, Hoogewoud, HM. (1991) Cerebral venography with MR. *Radiology* 178: 453-458.
- Meder, JF, Chiras, J, Roland, J, Guinet, P, Bracard, S, Bargy F. (1994) Venous territories of the brain. *J Neuroradiol* 21: 118-133.
- Mehta, NR, Jones, L, Kraut, MA, Melhem, ER. (2000) Physiologic variations in dural venous sinus flow on phase-contrast MR imaging. *Am J Roentgenol* 175: 221-225.
- Menegatti E, Zamboni P. (2008) Doppler hemodynamics of cerebral venous return. *Curr Neurovasc Res* 5: 260-265.
- Menegatti, E. Zamboni, P. (2008) Doppler Hemodynamics of Cerebral Venous Return. *Curr Neurovasc Res* 5: 260-265.
- Muizelaar, JP. (1989) Cerebral blood flow, cerebral blood volume, and cerebral metabolism after severe head injury. In *Textbook of Head Injury*, Becker, DP, Gudeman SK, Ed. Philadelphia: WB Saunders PA, pp. 221-240.
- Nylin, G, Hedlund, S, and Regnström O. (1961) Studies of the cerebral circulation with labeled erythrocytes in healthy man. *Circ Res* 9: 664-674.
- Ono, M, Rhoton, AL Jr, Peace, D, Rodriguez, RJ. (1984) Microsurgical anatomy of the deep venous system of the brain. *Neurosurgery* 15: 621-657.
- Okudera, T, Ohta, T, Huang, YP, Yokota, A. (1988) Developmental and radiological anatomy of the superficial cerebral convexity vessels in the human fetus. *J Neuroradiol* 15: 205-224.
- Parkinson, D. (2000) Extradural neural axis compartment. *J Neurosurg* 92: 585-588.
- Pedley, TJ, Luo, XY. (1998) Modeling flow and oscillations in collapsible tubes. *Theor Comput Fluid Dyn* 10: 277-294.
- Reisch, R, Vutskits, L, Filippi, R, Patonay, L, Fries, G, Perneczky, A. (2002) Topographic microsurgical anatomy of the parclinoid carotid artery. *Neurosurg Rev* 25: 177-183.
- San Millan Ruiz, D, Gailloud, P, Rufenacht, DA, Delavelle, J, Henry, F, Fasel, JH. (2002) The craniocervical venous system in relation to cerebral venous drainage. *Am J Neuroradiol* 23: 1500-1508.
- Schaller, B. (2004) Physiology of cerebral venous blood flow: from experimental data in animals to normal function in humans. *Brain Res Rev* 46: 243-260.
- Schreiber, S, Lürzing, F, Götze, R, Doepf, F, Klingebiel R, Valdueza, JM. (2003) Extrajugular pathways of human cerebral venous blood drainage assessed by duplex ultrasound. *Appl Physiol* 94: 1802-1805.
- Scott, JN, Farb, RI. (2003) Imaging and anatomy of the normal intracranial venous system. *Neuroimaging Clin N Am* 13: 1-12.
- Shenkin, HA, Harmel, MH, Kety, SS. (1948) Dynamic anatomy of the cerebral circulation. *Arch Neurol Psychiatry* 60: 240-252.
- Suzuki, Y, Ikeda, H, Shimada, M, Ikeda, Y, Matsumoto, K. (2001) Variations of the basal vein: identification using three-dimensional CT angiography. *Am J Neuroradiol* 22: 670-676.
- Takahashi, S, Sakuma, I, Omachi, K, Otani, T, Tomura, N, Watarai, J, Mizoi, K. (2005) Craniocervical junction venous anatomy around the suboccipital cavernous sinus: evaluation by MR imaging. *Eur Radiol* 15: 1694-1700.
- Teksam, M, Casey, S, McKinney, A, Michel, E, Truwit, CL. (2003) Anatomy and frequency of large pontomesencephalic veins on 3D



- CT angiograms of the circle of Willis. *Am J Neuroradiol* **24**: 1598-1601.
- Trolard P. (1868) Anatomie du système veineux de l'encephale et du crâne. Paris: *Thèse de la Faculté de Médecine de Paris*, pp. 1-32.
- Valdueva, JM, von Münster, T, Hoffman, O, Schreiber, S, Einhäupl, KM. (2000) Postural dependency of the cerebral venous outflow. *Lancet* **355**: 200-201.
- Vignes, JR, Dagain, A, Guerin, J, Liguoro, D. (2007) A hypothesis of cerebral venous system regulation based on a study of the junction between the cortical bridging veins and the superior sagittal sinus. *J Neurosurg* **107**: 1205-1210.
- Weissman, JL. (1994) Condylar canal vein: unfamiliar normal structure as seen at CT and MR imaging. *Radiology* **190**: 81-84.
- Wetzel, SG, Kirsch, E, Stock, KW, Kolbe, M, Kaim, A, Radue, EW. (1999) Cerebral veins: comparative study of CT venography with intraarterial digital subtraction angiography. *Am J Neuroradiol* **20**: 249-255.
- Wilson, EM, Halsey, JH, Vitek, JJ. (1972) Validation of jugular venous flow as an index of total cerebral blood flow. *Stroke* **3**: 300-320.
- Zamboni, P, Menegatti, E, Bartolomei, I, Galeotti, R, Malagoni, AM, Tacconi, G, Salvi, F. (2007) Intracranial venous hemodynamics in multiple sclerosis. *Curr Neurovasc Res* **4**: 252-258.
- Zamboni, P, Galeotti, R, Menegatti, E, Malagoni, AM, Tacconi, G, Dall'Ara, S, Bartolomei, I, Salvi, F. (2009a) Chronic cerebrospinal venous insufficiency in patients with multiple sclerosis. *J Neurol Neurosurg Psychiatry* **80**: 392-399.
- Zamboni, P, Menegatti, E, Galeotti, R, Malagoni, AM, Tacconi, G, Dall'ara, S, Bartolomei, I, Salvi, F. (2009b) The value of cerebral Doppler venous hemodynamics in the assessment of multiple sclerosis. *J Neurol Sci* **282**: 21-27.
- Zamboni, P. (2006) Iron-dependent inflammation in venous disease and proposed parallels in multiple sclerosis. *J R Soc Med* **99**: 589-593.